

**7011-C**  
**7011-S**  
**7111-S**

# 40-Channel Multiplexer Cards

## Quad 1x10 Multiplexer Configuration

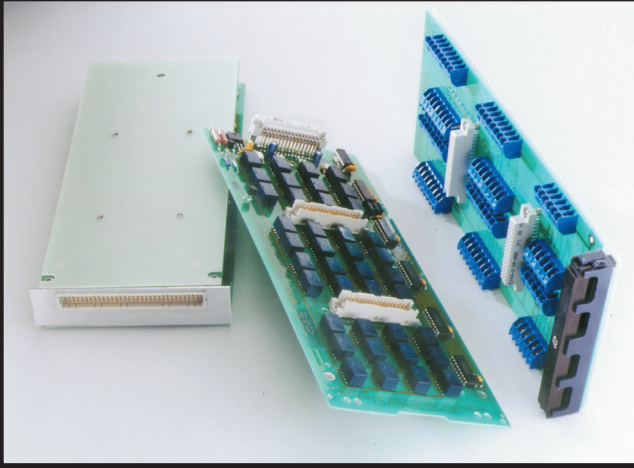

- Quad 1x10 multiplexer for 2-, 4-, or 8-pole operation
- Connects to 7001/7002 backplane for easy expandability
- 500nV, 100pA offsets

### Ordering Information

- 7011-C** Quad 1x10 Multiplexer with 96-Pin Mass Terminated Connector Board
- 7011-S** Quad 1x10 Multiplexer with Screw Terminal Connector Board
- 7111-S** Quad 1x10 Form C Multiplexer with Screw Terminal Connector Board

### ACCESSORIES AVAILABLE

#### FOR 7011-C:

7011-KIT-R	96-Pin Female Connector Kit
7011-MTC-1	96-Pin Mass Terminated Cable, Female to Female, 1m
7011-MTC-2	96-Pin Mass Terminated Cable, Female to Female, 2m
7011-MTR	96-Pin Male Connector Kit

#### FOR 7011-S AND 7111-S:

7011-ST	Extra Screw Terminal Connection Board
---------	---------------------------------------

The Model 7011 40-channel multiplexer has four independent banks of 1x10 switching. Each channel is 2-pole. These four banks can be combined for a wide variety of switching configurations—for example, dual 1x20, or 1x10 and 1x30, or one large 1x40. The 7001 mainframe can automatically configure the 7011 to switch 4-pole signals by combining channel pairs. This gives you a dual 1x10 4-pole multiplexer or a single 1x20 4-pole multiplexer.

Each of the four multiplexer outputs on this card connects to the 7001/7002 analog backplane through removable jumpers for even greater flexibility. Two 7011 cards can be used to make a single 1x80 multiplexer with all intercard connections through the backplane. The 7011 multiplexer outputs can also be connected to the rows of the 7012 via the backplane for row expansion.

The Model 7111-S is a form C version of the 7011-S. The 7111-S is a low-voltage, quad 1x10, single-pole form C multiplexer card. The 7111-S assembly consists of a screw terminal connector card and a relay card. External test circuits are wired directly to the screw terminals of the connector card.

These cards will automatically configure the 7001 or 7002 mainframe. Two connection options are available, screw terminal for maximum flexibility or a single 96-pin quick disconnect connector.

**MULTIPLEX CONFIGURATION:** Four independent 1x10 2-pole multiplex banks or two independent 1x10 4-pole multiplex banks. Adjacent banks can be connected together. Jumpers can be removed to isolate any bank from the backplane.

**CONTACT CONFIGURATION:** 2-pole Form A (Hi, Lo) (1-pole form C for 7111-S).

**CONNECTOR TYPE:**

**7011-C:** 96-pin male DIN connector.

**7011-S and 7111-S:** Screw terminal, #16AWG maximum wire size, with 0.092 inch O.D. 28 conductors per card maximum. #22AWG typical wire size with 0.062 inch O.D. 88 conductors per card maximum.

**MAXIMUM SIGNAL LEVEL:**

**DC Signals:** 110V DC between any two pins, 1A switched, 30VA (resistive load).

**AC Signals:** 125V rms and 175V AC peak, between any two pins, 1A switched, 60VA (resistive load).

**COMMON MODE VOLTAGE:** 175V peak, any pin to chassis.

**CONTACT LIFE:** Cold Switching: 10<sup>8</sup> closures. At Maximum Signal Levels: 10<sup>5</sup> closures.

**CHANNEL RESISTANCE (per conductor):** <1Ω.

**CONTACT POTENTIAL:** 7011-C: <1μV per channel contact pair <3μV typical per single contact. 7011-S, 7111-S: <500nV per channel contact pair <1.5μV typical per single contact.

**OFFSET CURRENT:** <100pA.

**ACTUATION TIME:** 3ms.

**ISOLATION:**

**Bank:** >10<sup>9</sup>Ω, <25pF.

**Channel to Channel:** >10<sup>9</sup>Ω, <50pF.

**Differential:** Configured as 1x10:  
>10<sup>9</sup>Ω, <100pF. Configured as 1x40:  
>10<sup>9</sup>Ω, <200pF.

**Common Mode:** Configured as 1x10:  
>10<sup>9</sup>Ω, <200pF. Configured as 1x40:  
>10<sup>9</sup>Ω, <600pF.

**CROSSTALK (1MHz, 50Ω Load):** Bank:  
<-40dB. Channel: <-40dB.

**INSERTION LOSS (50Ω Source, 50Ω Load):** <0.1dB below 1MHz, <3dB below 2MHz.

**RELAY DRIVE CURRENT (per relay):** 16mA.

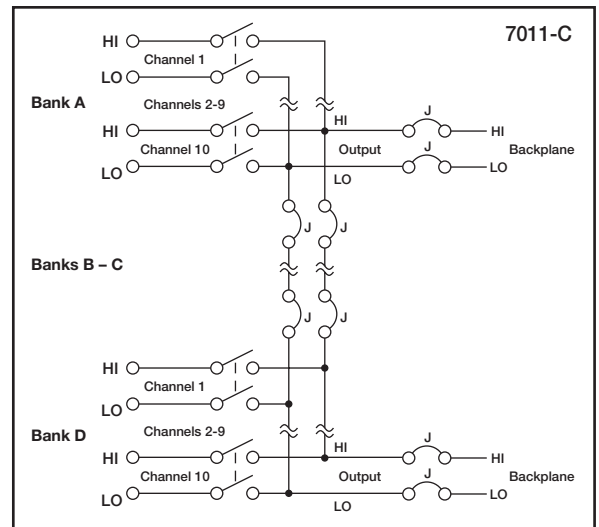

1.888.KEITHLEY (U.S. only)

www.keithley.com

**KEITHLEY**

A GREATER MEASURE OF CONFIDENCE

Use with 7001 and 7002 Switch Mainframes

SWITCHING & CONTROL